

SECOND FLOOR

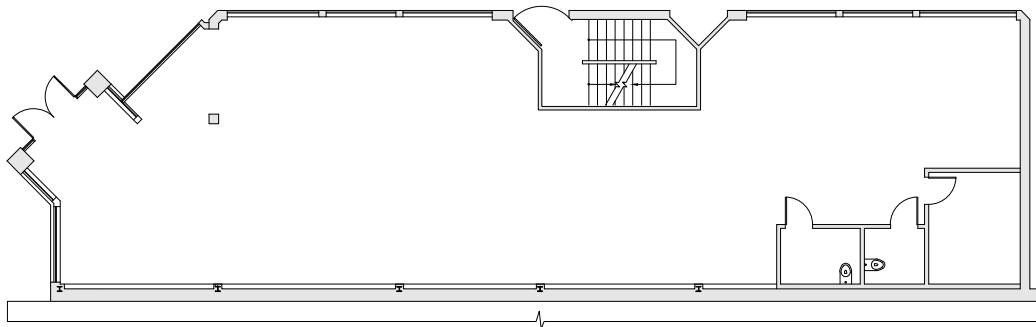

M STREET LEVEL

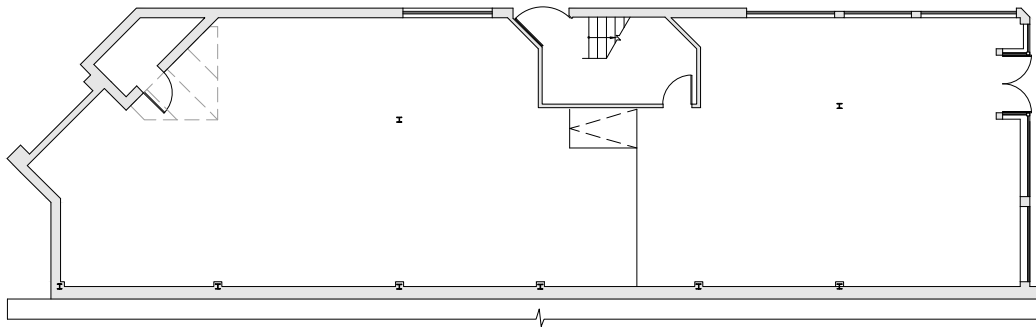

CADY'S ALLEY LEVEL

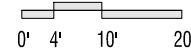

FLOOR	NET RENTABLE AREA	COMMON AREA
B-T2	2,867 SF	176 SF
G-T1	2,812 SF	176 SF
2-T1	901 SF	116 SF
2-T2	211 SF	27 SF
2-T3	1,486 SF	191 SF
TOTAL	8,277 SF	686 SF

33RD ST NW

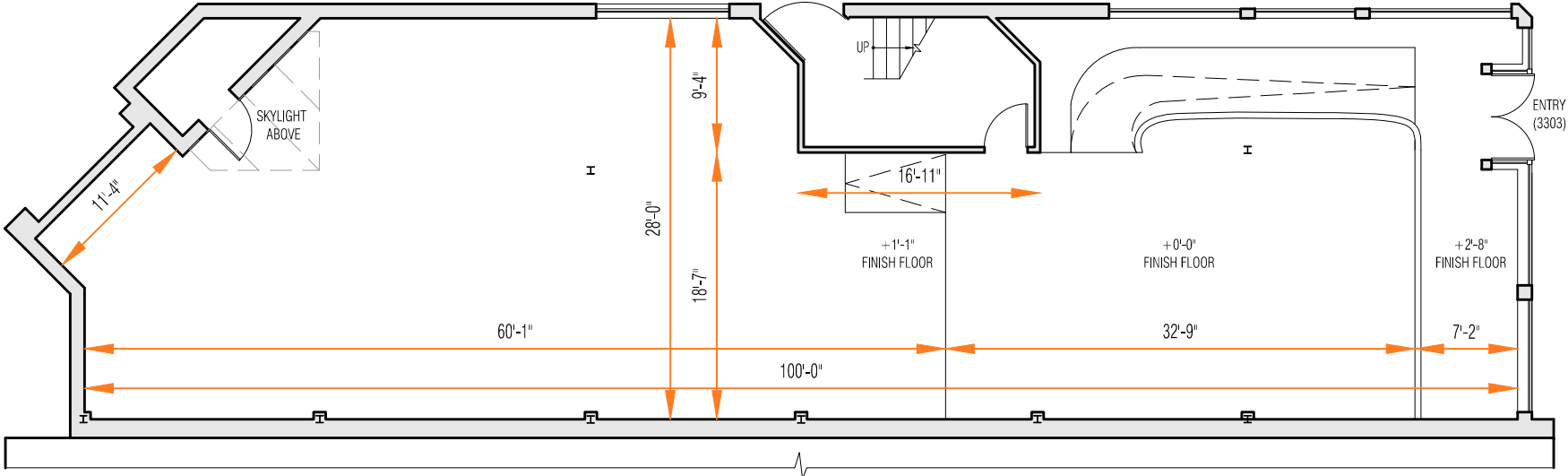

CADY'S ALLEY

GROSS RENTABLE AREA : 3,043 SF

NET RENTABLE AREA : 2,867 SF

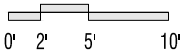

33RD ST NW

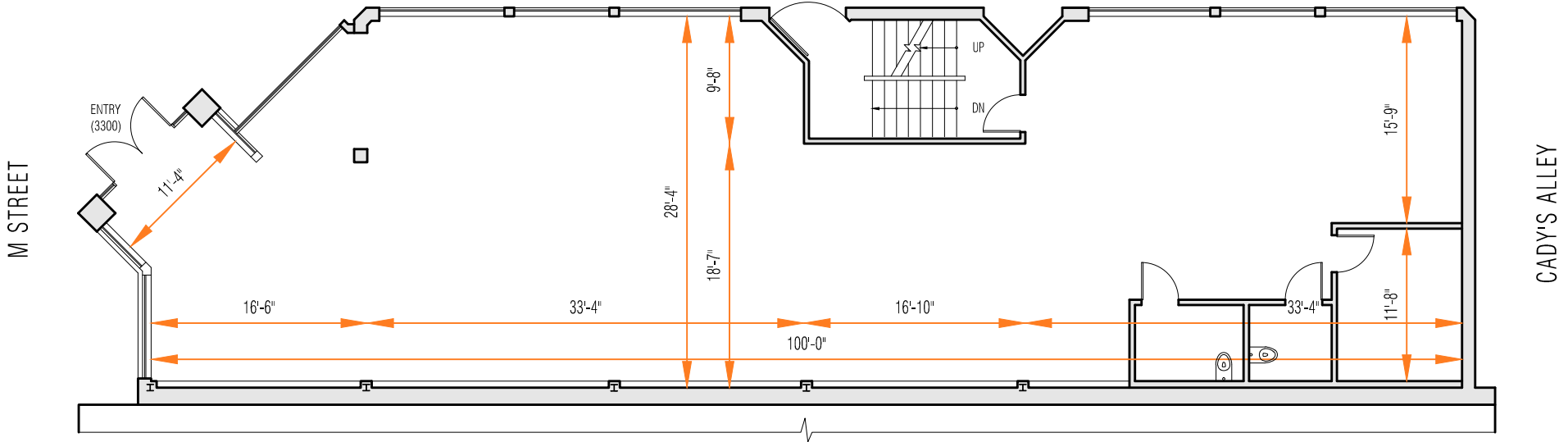

GROSS RENTABLE AREA : 2,988 SF

NET RENTABLE AREA : 2,812 SF



STUDIOTWENTYSEVENARCHITECTURE
JUNE 30, 2017

M STREET LEVEL - TENANT 1

EastBanc

3300 M STREET NW
WASHINGTON, D.C.

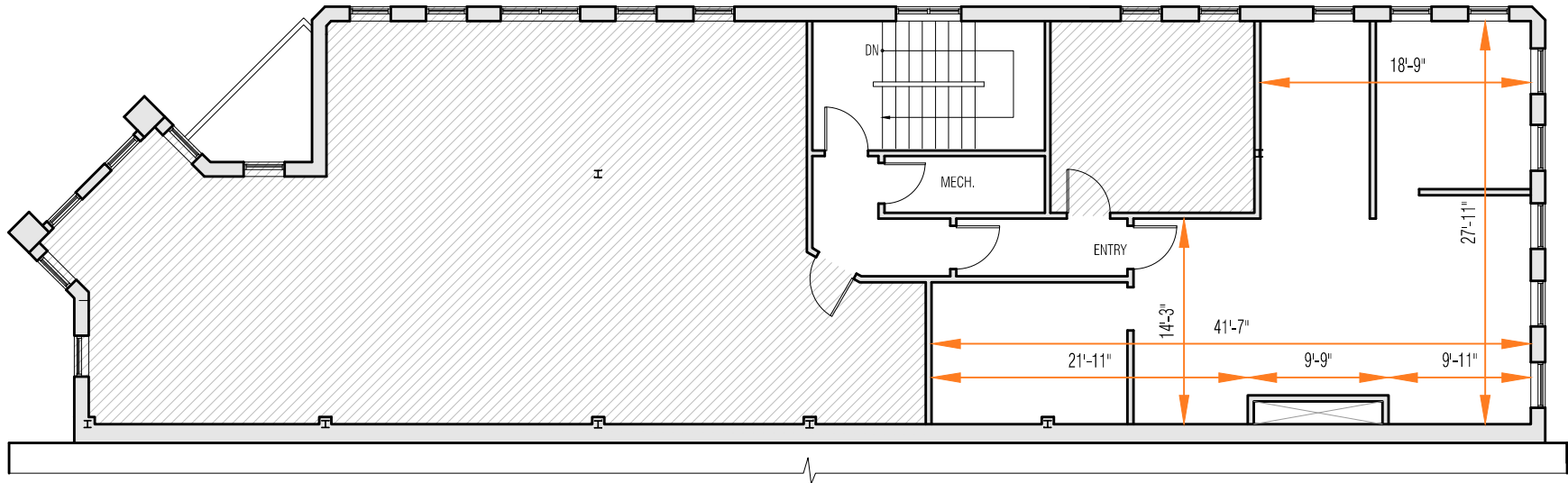

GROSS RENTABLE AREA : 1,017 SF

NET RENTABLE AREA : 901 SF

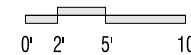

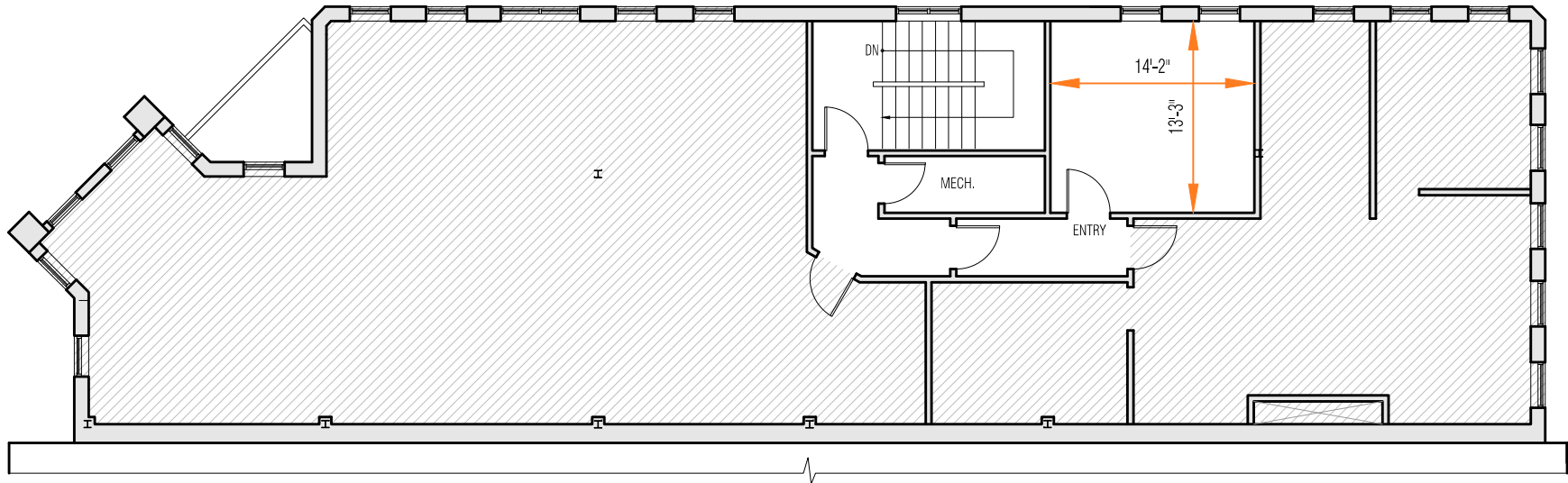

GROSS RENTABLE AREA : 238 SF

NET RENTABLE AREA : 211 SF

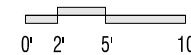

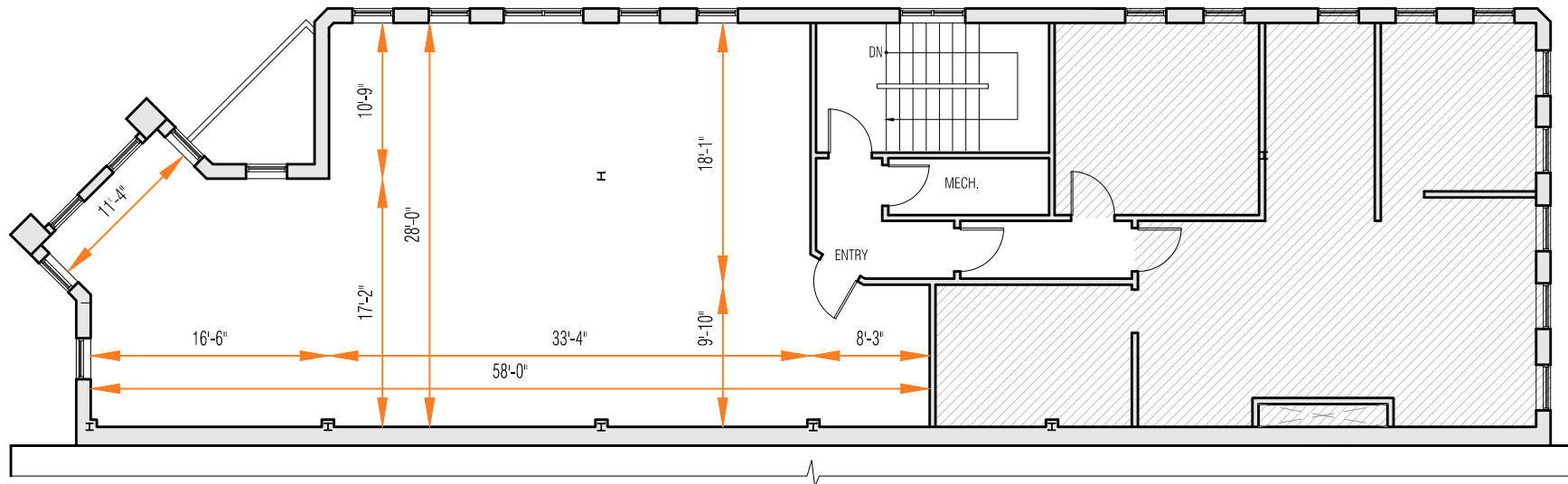

GROSS RENTABLE AREA : 1,677 SF

NET RENTABLE AREA : 1,486 SF

